

# CX5-L

## Specifications

---

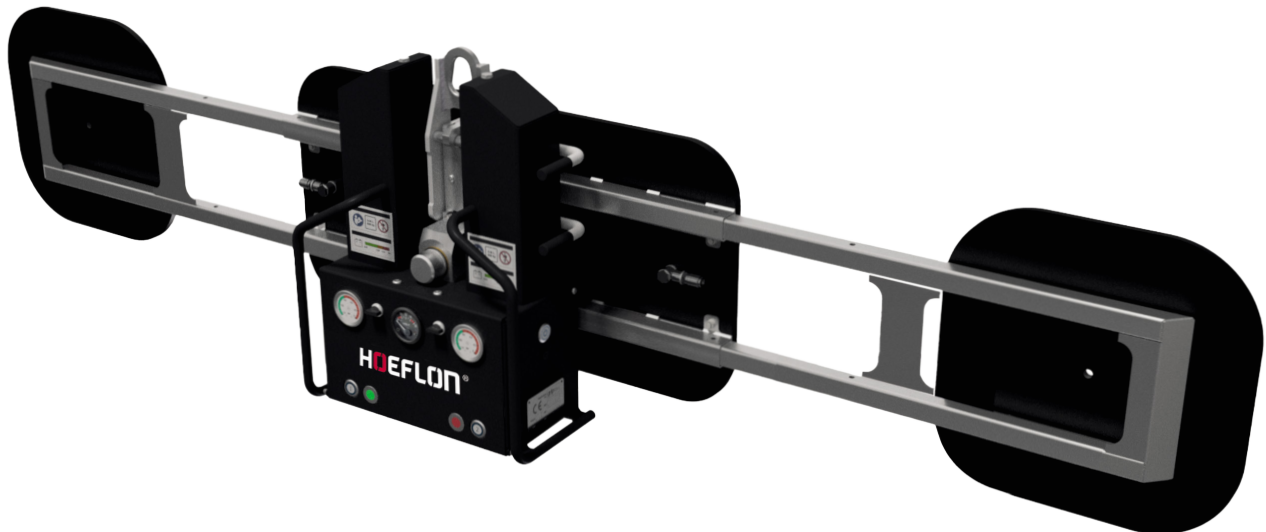

<b>Lifting capacity double circuit:</b>	250 - 500 kg
<b>Machine weight:</b>	50 kg
<b>Rotation range:</b>	360° with four locking positions
<b>Tilting range:</b>	90° with three locking positions
<b>Machine height:</b>	240 mm
<b>Battery:</b>	12 VDC, 9 Ah

The vacuum lifter for glass up to 500 kg. Standard equipped with a double circuit. The various configurations make this machine our all-rounder, suitable for small and large projects.

## Unique features

- Lightweight 40 kg base unit with 250 kg SWL
- Expandable up to 2200 mm and 500 kg SWL
- Compact base dimensions of 800 x 400 mm
- Full double circuit for highest possible safety
- Machine weight: 50 kg

## Delivered standard with:

- Remote control
- Transport trolley
- Battery charger
- Protective cover
- Hoisting arm extension



Battery charger



Remote control

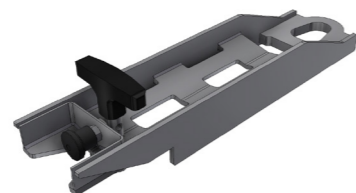

Hoisting arm extension



Trolley & PVC cover

## Specifications

- Manual tilting with three locking positions and continuous adjustment
- Manual rotation with four locking positions
- Radio remote control for suction and release
- Interchangeable lifting point for lower overall height
- Transport trolley with pneumatic tyres

## Dimensions

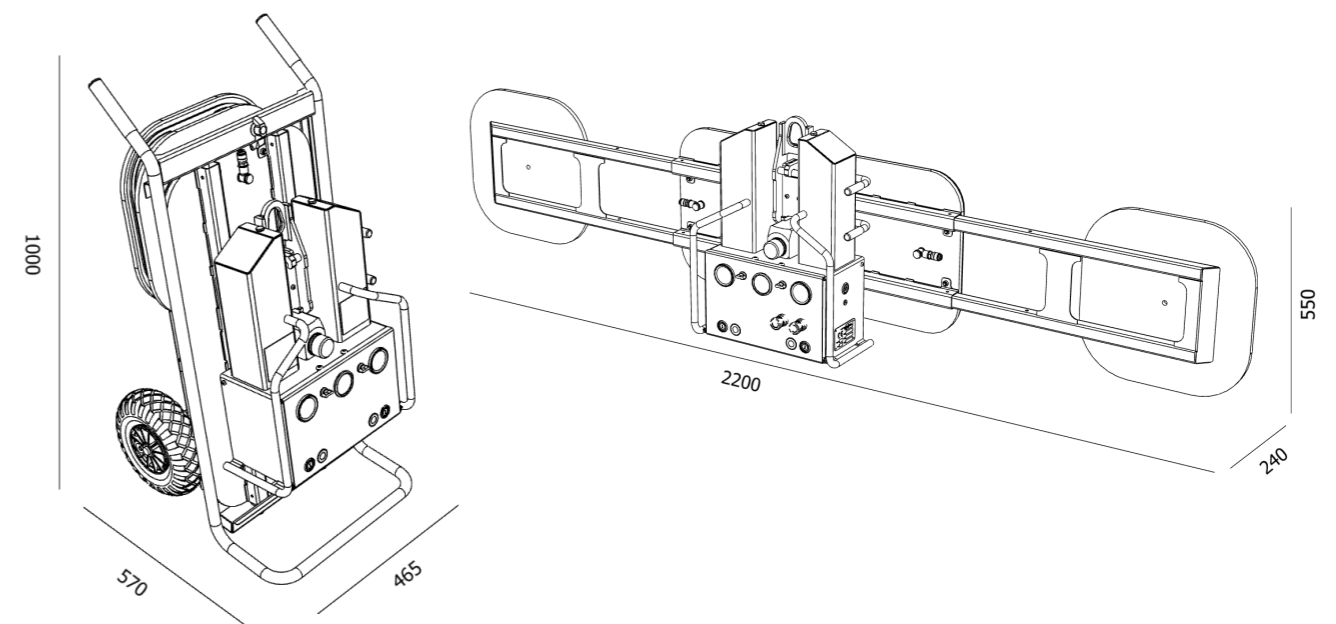

## In-use

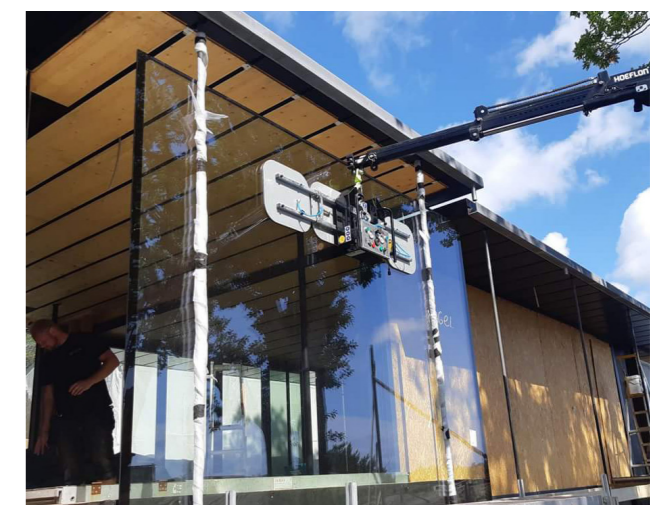

## See what the CX5-L can do for you

Hoeflon glass lifters are built for precision, safety, and ease of use: ready to support any lifting challenge on your job site. Interested in seeing the performance for yourself or receiving more information? Get in touch to request a demo or quote.

