

S800

Specifications

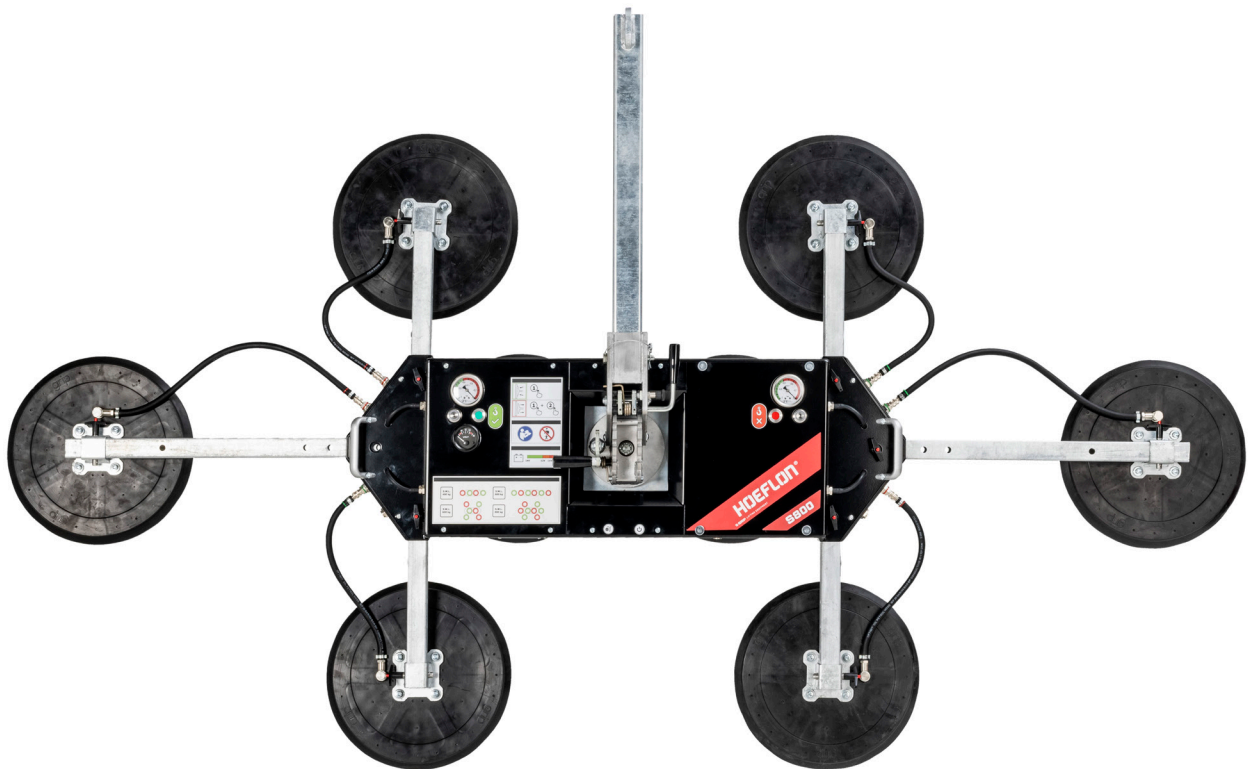

Lifting capacity double circuit:	200 - 800 kg
Machine weight:	55 - 80 kg
Rotation range:	360° with four locking positions
Tilting range:	90° with six locking positions
Machine height:	200 mm
Battery:	12VDC, 10Ah

The Hoeflon S800 suction lifter is a premium quality multifunctional glass lifter, with exceptional fit and finish, at a very competitive price.

All our products are designed in-house in close cooperation with users from the field. This results in products that are a class apart when it comes to the details and provide the user with every convenience in daily use.

Unique features

- Lifting capacity from 200-800 kg with dual-circuit vacuum system
- 360° rotation with four locking positions for controlled handling
- 90° tilting range with six locking positions for precise positioning
- Extremely compact and lightweight design: only 55-80 kg depending on configuration

Delivered standard with:

- Remote control
- Transport trolley
- Exchangeable lifting arm
- Exchangeable battery system incl. spare battery
- Protective covers for suction cups



Battery



Charger



Remote control



Exchangeable lifting arm



Cover set suction cups & trolley

Optional accessories



PVC cover

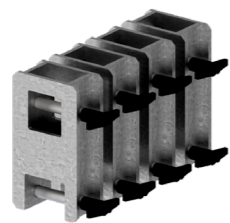

Raised support set
9 cm

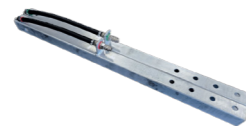

Extension tube set
2.6 cm

Specifications

- Extra-short lifting arm ensures extremely compact dimensions when handling glass in confined installation spaces.
- Angle adjustment on the Hoeflon lifting arm provides extra safety and convenience for indoor glazing installation because the angle can be fixed in different positions.
- Double vacuum circuit, meeting the requirements of the EN 13155 directive, ensures maximum safety and installation speed because external load fall arrester is no longer necessary.
- Radio remote control provides extra installation speed and convenience.
- The overall width of the machine is very low, which means that work can also be carried out between the facade and scaffolding.

In-use



SWL 800 kg - Spider suction lifter

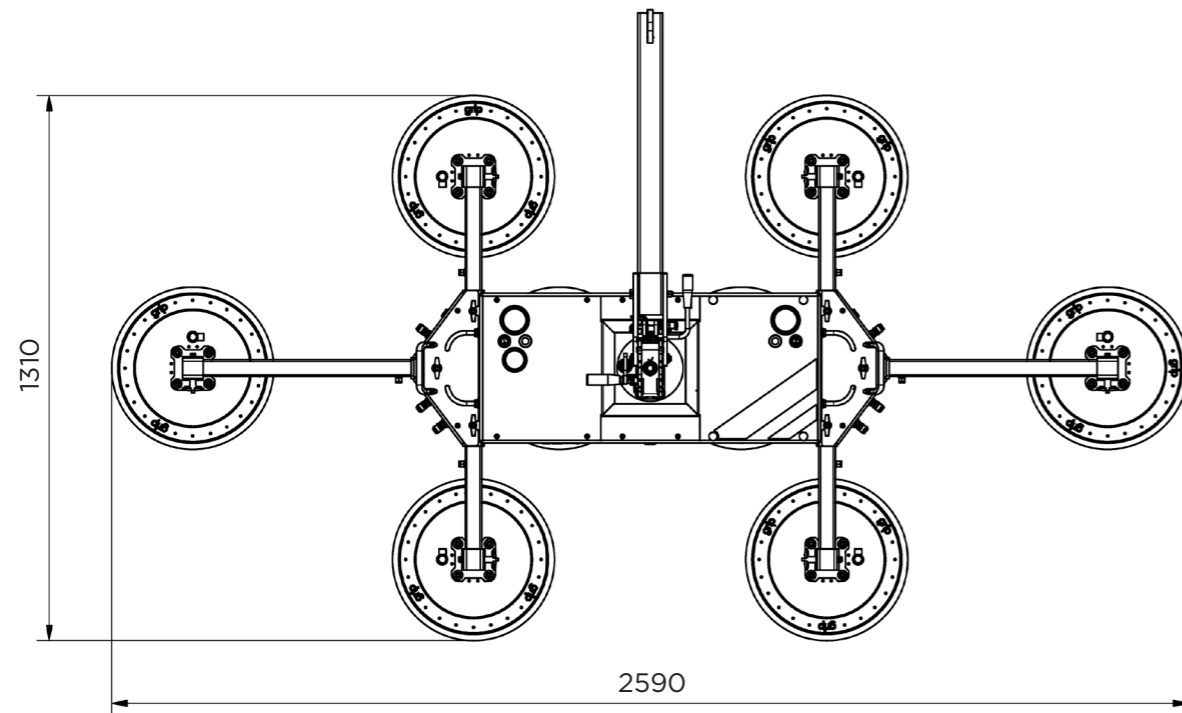

SWL 400 kg - Inline suction lifter

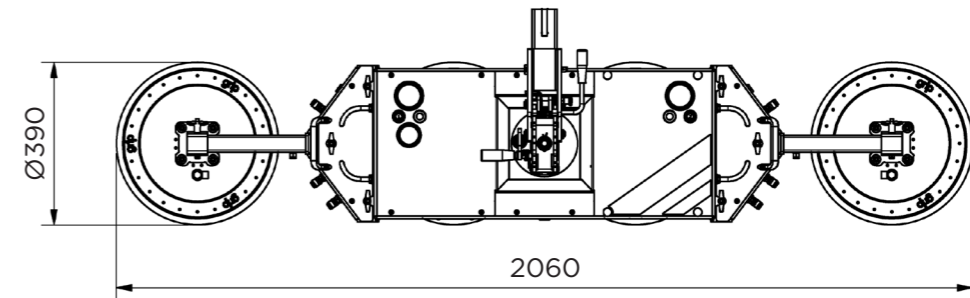

SWL 600 kg - Inline suction lifter

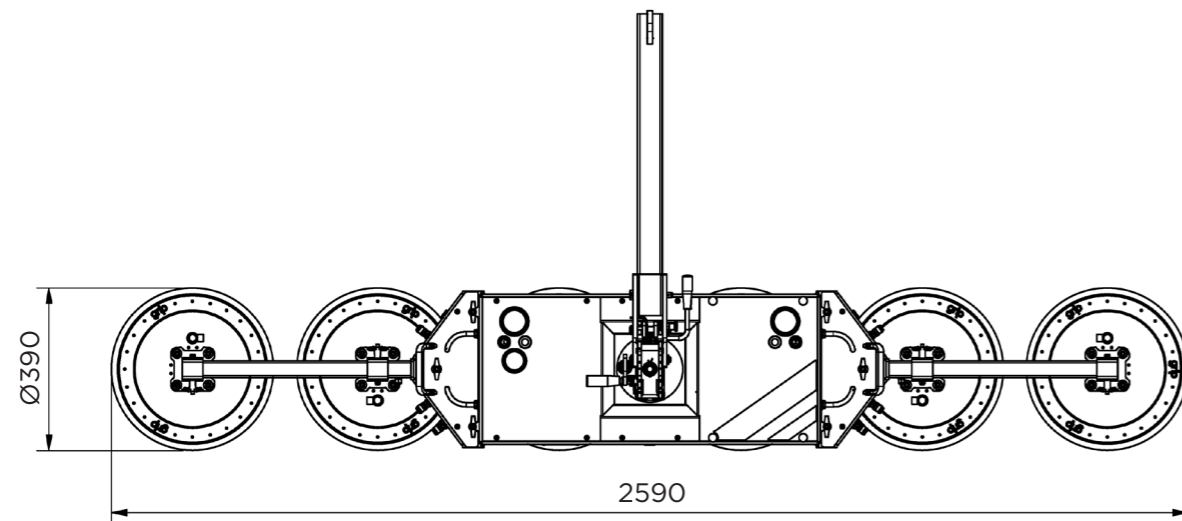

SWL 200 kg - Base unit

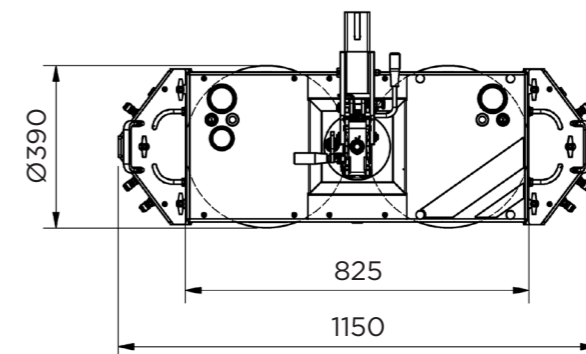

S800

Specifications

HOEFLON[®]

See what the S800 can do for you

Hoeflon glass lifters are built for precision, safety, and ease of use: ready to support any lifting challenge on your job site. Interested in seeing the performance for yourself or receiving more information? Get in touch to request a demo or quote.



Hoeflon International B.V.

Zwolleweg 2

3771 NR Barneveld, NL

T +31 (0)342 400288

sales@hoeflon.com

KVK 66408962

BIC ABNANL2 A

BTW NL856539806B01

IBAN NL96ABNA0457114533

www.hoeflon.com